

# Punching Machine AVP

Presses for PVC/PU Conveyor Belts > Belt preparation

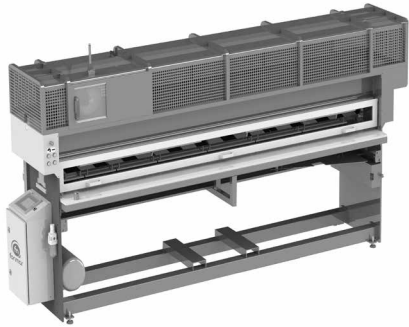

Material	Frame - Steel Blades - Steel
Pressure	Pneumatic
Blades/Knives	80x10   50x20   Cross cutting (other ones upon request)

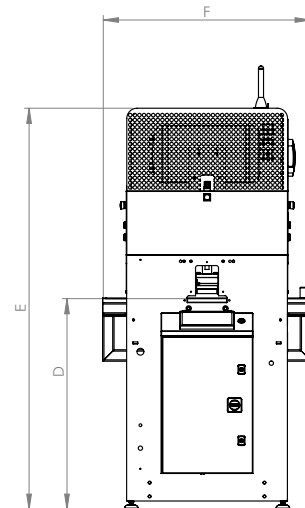
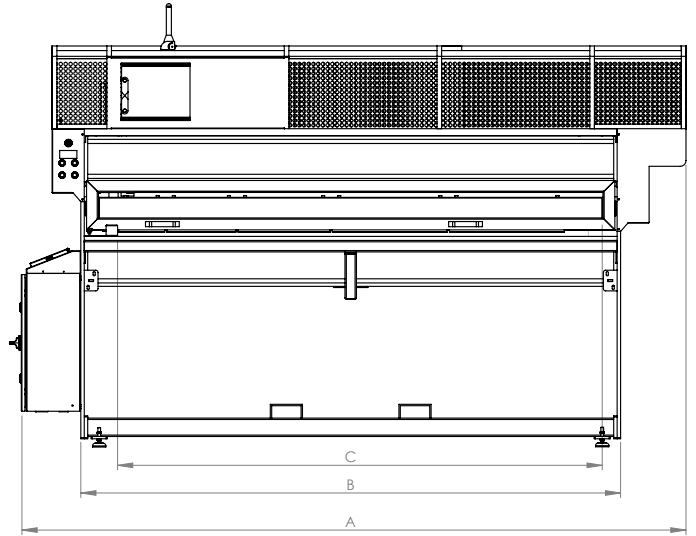

	A	B	C	D	E	F	Total weight
Model	mm	mm	mm	mm	mm	mm	Kg
AVP 2000	2890	2350	2100	917	1746	910	915
AVP 3000	3890	3350	3100	917	1746	910	1100

The technical data shown are subject to change without notice.