

# EPSILON

Pressen für PVC/PU-Förderbänder > Montagepressen > Mittels Wasser gekühlt

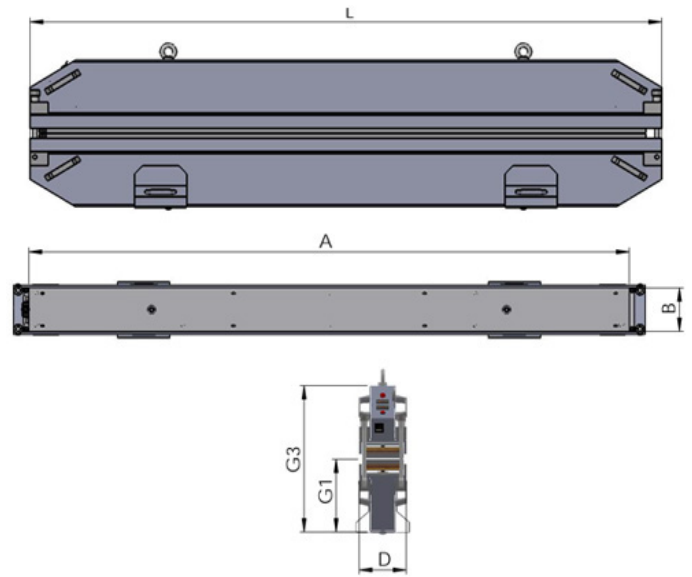
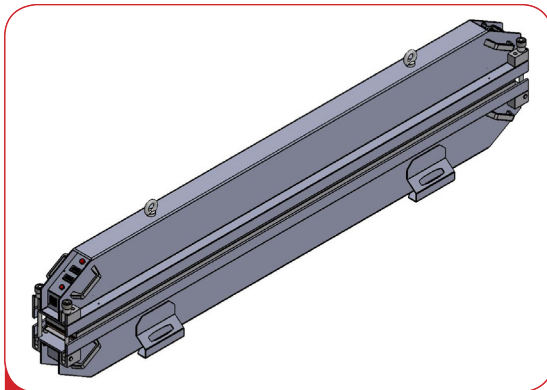

Material	Aluminium
Druck	Luftkissen oben & unten 2 Bar
Heizung	gepanzerte Widerstandsheizung Max. 200°C
Kühlung	Wasser
Bandbreite	Bis 3600mm
Heizplattenbreite	160mm
Winkel	90°

	Banda	G1	G3	A	B	D	L	Gewicht u. Element	Gewicht o. Element	Gesamtgewicht
Modell	mm	mm	mm	mm	mm	mm	mm	Kg	Kg	Kg
Epsilon 1600	1600	217	434	1700	180	160	1820	42.4	46.8	89.2
Epsilon 1800	1800	217	434	1900	180	160	2020	47.4	50.0	97.4
Epsilon 2000	2000	267	534	2100	180	160	2220	57.0	59.5	116.5
Epsilon 2200	2200	267	534	2300	180	160	2420	61.6	65.4	127.0
Epsilon 2400	2400	347	694	2500	180	160	2620	64.0	68.0	132.0
Epsilon 2600	2600	347	694	2700	180	160	2820	67.7	71.5	139.2
Epsilon 2800	2800	417	834	2900	180	160	3020	89.5	93.5	183.0
Epsilon 3000	3000	417	834	3100	180	160	3220	95.3	99.4	194.7
Epsilon 3200	3200	417	834	3300	180	160	3420	108.8	112.8	221.6
Epsilon 3600	3600	320	640	3700	180	160	3920	165.0	156.0	321.0

Die angezeigten technischen Daten können ohne vorherige Ankündigung geändert werden.