

DELTA AR

Pressen für PVC/PU-Förderbänder > Für Werkstatt

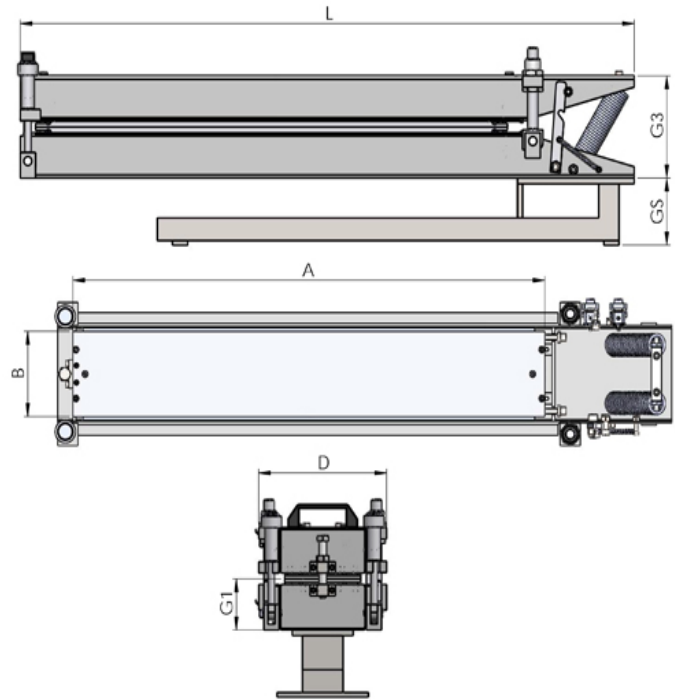
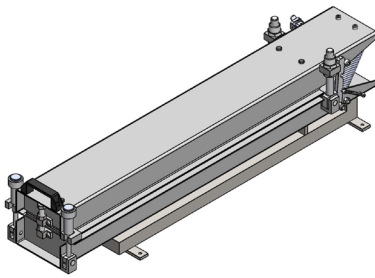

Material	Stahl
Druck	Luftkissen oben & unten 3 Bar
Heizung	gepanzerte Widerstandsheizung Max. 200°C
Kühlung	Wasser
Bandbreite	Bis 1500mm
Heizplattenbreite	60mm - 100mm - 150mm
Winkel	90°

Das Gesamtgewicht beinhaltet Untersatz.

Modell	Band mm	G1 mm	GS mm	G3 mm	A mm	B mm	D mm	L mm	innerer Perimeter mm	Gesamtgewicht Kg
Delta AR 300x60	300	92	118	184	430	60	162	705	326	25
Delta AR 300x100	300	92	118	184	430	100	202	705	406	49
Delta AR 300x150	300	92	118	184	430	150	252	710	-	77
Delta AR 400x60	400	92	118	184	530	60	162	805	326	29
Delta AR 400x100	400	92	118	184	530	100	202	805	406	52
Delta AR 400x150	400	92	118	184	530	150	252	810	-	80
Delta AR 600x60	600	92	118	184	730	60	162	1005	326	35
Delta AR 600x100	600	92	118	184	730	100	202	1005	406	59
Delta AR 600x150	600	92	118	184	730	150	252	1010	-	87
Delta AR 800x60	800	93	118	186	930	60	164	1205	326	42
Delta AR 800x100	800	93	118	186	930	100	204	1205	406	66
Delta AR 800x150	800	93	118	186	930	150	254	1210	-	94
Delta AR 1000x60	1000	93	118	186	1200	60	164	1475	326	49
Delta AR 1000x100	1000	93	118	186	1200	100	204	1475	406	73
Delta AR 1000x150	1000	93	118	186	1200	150	254	1480	-	101
Delta AR 1200x60	1200	94	118	188	1330	60	166	1605	326	55
Delta AR 1200x100	1200	94	118	188	1330	100	206	1605	406	79
Delta AR 1200x150	1200	94	118	188	1330	150	256	1610	-	107
Delta AR 1500x60	1500	94	118	188	1630	60	166	1905	326	66
Delta AR 1500x100	1500	94	118	188	1630	100	206	1905	406	89
Delta AR 1500x150	1500	94	118	188	1630	150	256	1910	-	117

Die angezeigten technischen Daten können ohne vorherige Ankündigung geändert werden.